

ECCLESIASTICAL SEATING LUKE HUGHES AND COMPANY OPTIONS



Introduction	5
Church Seating - a short history	6
Luke Hughes & Company seating options	7
Stacking pew benches	9
St John's, Notting Hill	10
St George's, Bloomsbury	11
Chichester Cathedral, Lady Chapel	12
specifications, features & benefits	13
'Assembly' oak stacking, linking chairs	15
Dorchester Abbey	16
Canterbury Cathedral	17
Arundel Cathedral	18
specifications, features & benefits	19
'Daylight' reinforced resin stacking chairs	21
specifications, features & benefits	23
Sponsorship & fund raising	25
Useful contacts	26
Client comments	27

INTRODUCTION

There are 16,200 church buildings; 76% are listed, 4,200 are listed Grade I, and that comprises 45% of all Grade I buildings in the country. Dwindling congregations, demand for multiple community use and changes in liturgy and approaches to worship have all conspired to demand some flexibility in ecclesiastical spaces.

Cathedrals tend to serve broader communities than parish churches. These may include regular worshippers but often the visitors are more transitory: civic or county dignitaries, the diocesan team, local schools, worshippers in Holy Week, and more obviously tourists (who, one hopes, may be turned into pilgrims). They all use the space for different purposes: for private prayer and reflection, for corporate worship, for meetings and conversation, for concerts and drama, for educational assemblies, or just for a nice day out (there were 32.4m visitors to a UK cathedral in 2001).

Conversely, what may work for an 11th century Romanesque cathedral may not be appropriate to an Early Perpendicular rural parish church. Congregations may be high or low, active or passive, traditional or evangelical. But it is clear they are seeking flexible, welcoming spaces, and improved comfort - not just from the seats but perhaps also (thanks to improvements in under-floor heating technology), the climate.

Constraints come from Diocesan Advisory Committees and, especially in listed buildings, architectural lobby groups who have legitimate concerns about alterations to historic fabric, and indeed to the impact any seating changes may have on the internal landscape. But there may also be others: fire officers may be concerned about the safety of linking rows; promoters of music festivals may have views about the commercial possibilities; the PCC may be concerned about provision for Youth Club evenings.

So when it comes to seating for churches, the question is not just one of buying new chairs; it is about running a major community building (probably of considerable architectural excellence), albeit one that may be steeped in history, sentiment and splendour.

This booklet helps set out some of the practical issues and design considerations when selecting seating for ecclesiastical buildings. It also includes some practical information, not least about fund-raising and the contact details of supporting organisations.





In any quality building, the connection between architecture and furniture design should be seamless. Most buildings cannot function until they have furniture in them, and inappropriate pieces grossly undermine great architecture. This is particularly the case for churches where the design criteria for furnishings demand higher things than merely commodity, firmness and delight.



In truth, the most impressive spiritual interiors, especially naves, look better with no furniture at all (think of Cistercian abbey churches) but clearly modern liturgy and usage requires the minimum pieces of furniture necessary to sustain it.



Few churches had any seating until the late 17th century and, like Greek Orthodox churches today, naves were largely left empty, their internal spaces capable of being seen as they were intended. We see this in contemporary Dutch paintings of church interiors. Floor patterns are revealed; the connection between the paving and column bases makes aesthetic sense; the proportions of arcades are uninterrupted. During a service, congregations stood or wandered. The old and infirm could 'go to the wall', or sit on the low stone benches built on the outside walls of the side aisles.



After the Reformation, the requirement to listen to sermons gave rise to the idea that a congregation could sit, albeit in serried ranks on benches and preferably in a social pecking order. But it was not until the late 17th century that pews began to be installed as an integral part of the church design. For example, in Wren's city churches, the pews relate closely to the marble floor grid and the seats are made out of oak with raised and fielded panels - quite as fine as any other joinery work in the building.



However, it was not really until the ecclesiastical revival in the late 19th century that architects began in earnest to try and put long, heavy (if not immovable) pews into churches for which they were simply not designed. Once in place they were not only impractical to move but also a restraint on the scope for communication. But they were at least neutral in



design terms and, generally, made minimal impact on the setting. It was not really until the late 19th century that chairs could be made in large quantities at affordable prices. Indeed the evolution of seating in churches has much to do with the economics of production - before the Industrial Revolution, even sawing long planks for pews was an expensive business.

We are now in an age when 're-configurability' is the understandable cry. We may not quite want to billet our troops (Durham Cathedral in the 1640's) or garage our fire-engine (Romsey Abbey in the 1760's) or have aristocratic family members parade in canopied box pews; but we do want to use our churches for different levels of worship, and to involve communities for meetings, plays and concerts in varying degrees. There may also be a requirement for different styles of worship - ranging from a crowded family service with orchestral ensemble to an intimate gathering for Iona prayer. Whatever liturgical changes might come in the next century can be better accommodated if the furniture can be moved.



Chairs have seemed the obvious solution and parishes have rushed into stripping out the pews and replacing them with the cheapest option. But, as with so many things, the easiest solution is rarely the best. Most modern chairs are just not designed for the space. What might work in a 1960's parish hall is unlikely to fit the finest Baroque buildings in the country. What may suit a small, private side chapel may not suit the main body of a nave.



In this booklet we examine the factors and set out some of the criteria that might be employed to ensure that designs are indeed sympathetic to their setting, comfortable and cost effective. It is our aim to produce seating that is compatible, dignified, practical and long-lasting. And, of course, subservient to the architecture.

Luke Hughes & Company's solution has been to produce three product ranges which address all issues:

STACKING PEW BENCHES

stacking, removable pews

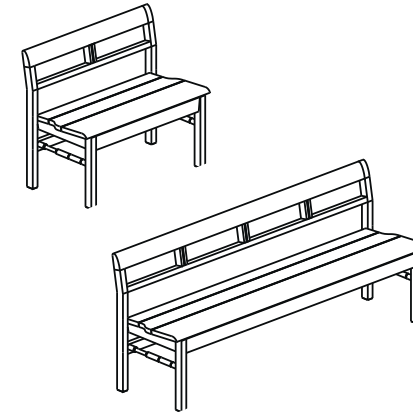

ASSEMBLY

solid oak stacking, linking chairs

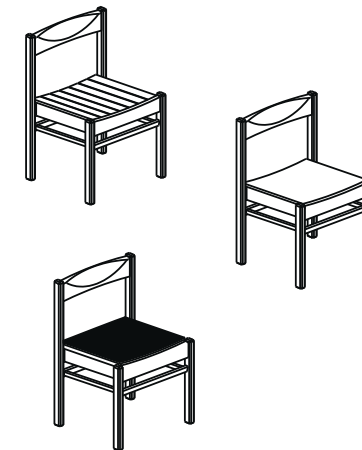

DAYLIGHT

reinforced resin stacking chair



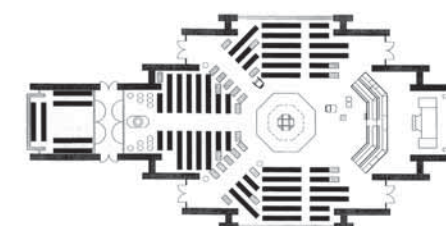
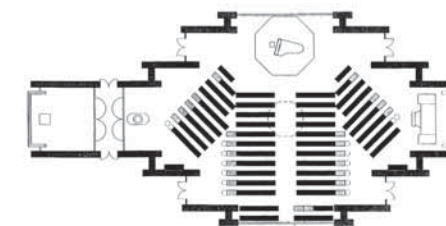
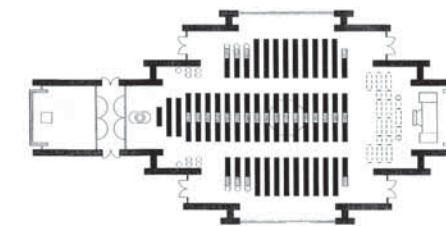

Perhaps the greatest dilemma of church seating revolves around the choice of chairs or pews. Pews are normally uncomfortable and cumbersome to move, yet they tend to look better than chairs. Conversely, chairs afford easier configuration, but are both visually distracting and time consuming to move around in quantity. The answer? The stacking pew bench.

STACKING PEW BENCHES - 'CRANLEIGH' BENCHES AT ST JOHN'S, NOTTING HILL



STACKING PEW BENCHES - 'HAWKSMOOR' BENCHES AT ST GEORGE'S, BLOOMSBURY

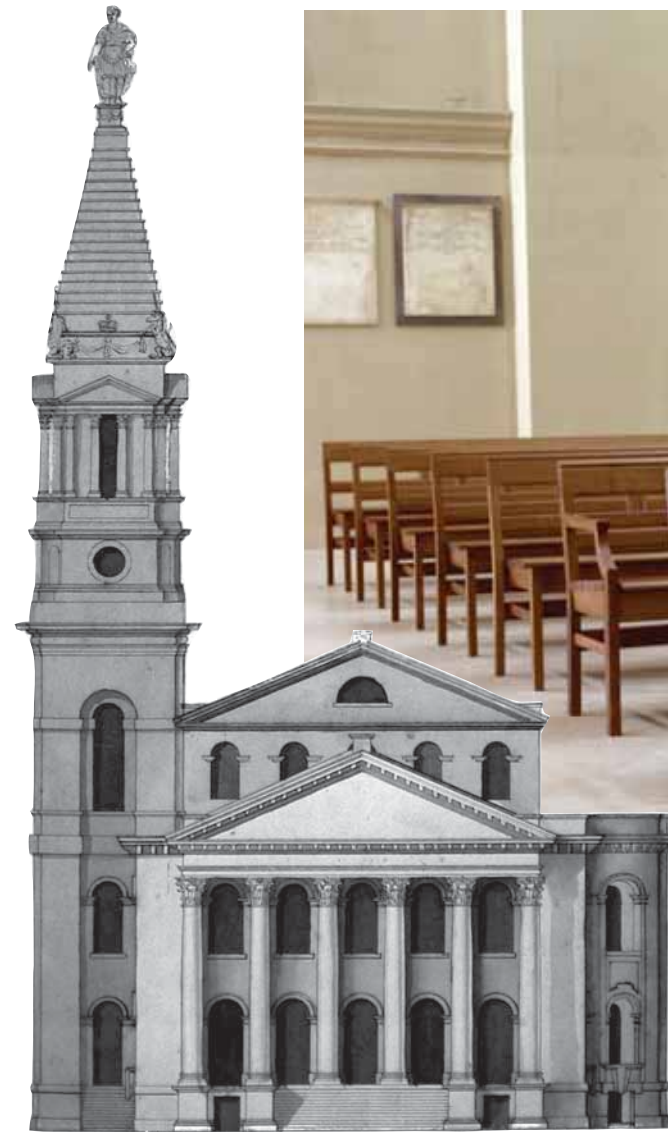

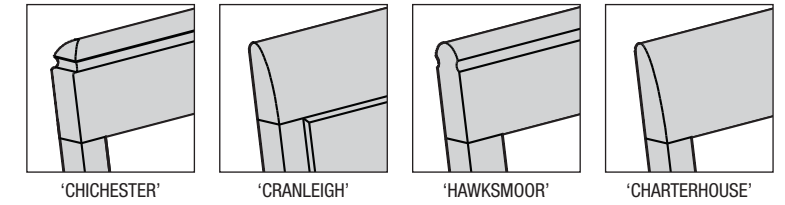
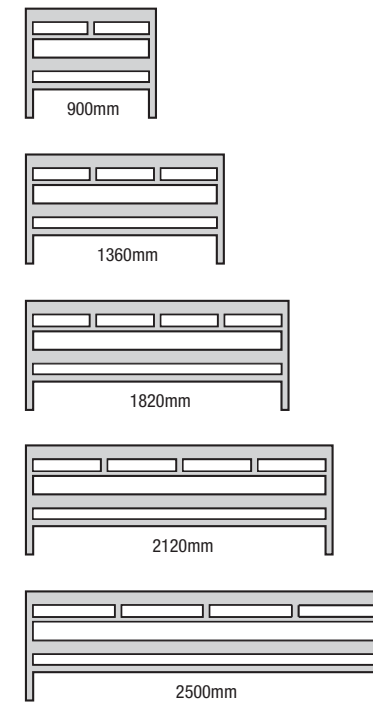

	overall height	seat height	seat width	overall depth	seat depth	stack
All 4 styles	773	436	896	481	448	5 high

- 3 standard colours
- 4 different styles
- 5 standard sizes
- Extras include non-standard lengths, shelf for hassocks or kneelers, arms, trolleys and special stain colours



PEW BENCHES	FEATURES	BENEFITS
Stacking, removable bench / pew, best suited for parish churches, school chapels, movable choir areas		Congregations can bunch up; an average 300-seat church with benches (rather than chairs) can accommodate 15-20% more people, <i>in extremis</i> ; very useful for clearing a nave or choir; ideal for churches that must be rearranged or cleared for concerts, plays or other community functions
	Restrained appearance with refined modelling	Minimal impact on interior architecture; particularly well suited for sensitive architectural settings
	Looks good when stacked	No need to hide them when stored in side aisles etc.
	Favoured by SPAB, English Heritage, Georgian Group, Victorian Society and other conservation groups	Less likely to be contentious in DAC Faculty applications when seeking to remove pews
	Solid oak	Patinates gracefully; compatible with most church furnishings; highly resistant to rot or insect attack; virtually maintenance free
	Links	Optional - but not strictly necessary; congregation can sit over the join
	Ergonomic	Much more comfortable than conventional pews; lower rails allow elderly and disabled to get their weight over their feet when standing up; rounded edges minimise scuffing and are pleasant to touch
	Stacks 5/6 high	Economic storage
	5 standard sizes	Enables the benches to be made to fit a particular aisle width
	Modifications possible to colour	Adaptable for sensitive church interiors of any age
	Storage trolleys available	For ease of storage
	Light	2 people can clear a 300 seat church in 17 minutes
	Stable	Designed to be stable if the elderly or infirm place their weight for support; minimal realigning of rows in daily use
	50-100 year life expectancy	Exceptional investment



'ASSEMBLY' OAK STACKING, LINKING CHAIRS



If chairs are the best answer, they should have a timeless appearance, look good when stacked or viewed in rows, offer a 50-100 year life expectancy. The ASSEMBLY chair was designed for Canterbury Cathedral and complies fully with these criteria.

'ASSEMBLY' OAK STACKING, LINKING CHAIRS - DORCHESTER ABBEY



'ASSEMBLY' OAK STACKING, LINKING CHAIRS - CANTERBURY CATHEDRAL



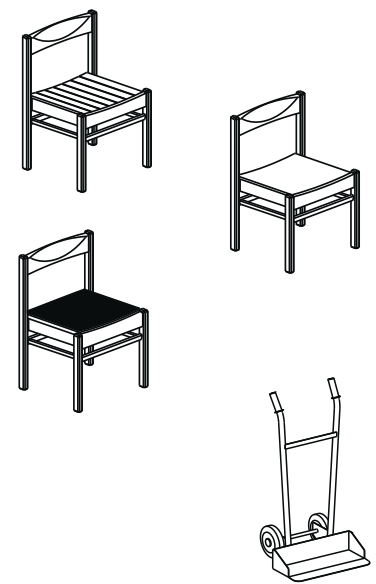

	overall height	seat height	overall width	seat width	overall depth	seat depth	stack
slatted, veneered, upholstered*	782	441	524	454	472	433	5 high



	overall height	overall width	Chair Capacity
sack truck	1130	529	4

* minimum 50 order

ASSEMBLY	FEATURES	BENEFITS
Solid oak stacking chairs best suited for chancel areas, side chapels, chapter-houses, parish churches	Restrained appearance with refined modelling	Minimal impact on interior architecture; particularly well suited for sensitive architectural settings
	Looks good when stacked	No need to hide them when stored in side aisles etc.
	Solid oak	Patinates gracefully; compatible with most church furnishings; highly resistant to rot or insect attack; virtually maintenance free
	Links	Optional
	Comfortable	Much more comfortable than conventional pews; lower rails allow elderly and disabled to get their weight over their feet when standing up; rounded edges minimise scuffing and are pleasant to touch
	Stacks 5/6 high	Economic storage
	Optional shelf for hymn-book and hassocks	No hooks or clutter; shelf does not interfere with stacking facility
	Modifications possible to colour	Adaptable for sensitive church interiors of any age
	Storage trolleys available	For ease of storage
	30-50 year life expectancy	Good medium term investment



'DAYLIGHT' - REINFORCED RESIN STACKING CHAIRS



Daylight, an ergonomic, ecologically sound stacking chair with light mesh back and seat. Frame parts for the back and seat are 100% recycled plastic. The chair weighs less than 4kg, about 40% lighter than other stacking chairs on the market and stacks up to 45 high on the dolly. Strong and flexible mesh provides optimum flex and tension in the back as well as breathability.

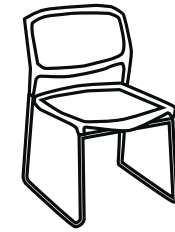

stacking chair

Overall height	Seat height	Overall width	Seat width	Overall depth	Seat depth
820	470	490	445	550	480

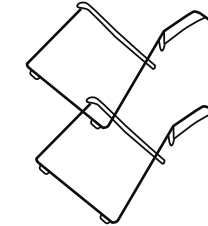

1 tier chair trolley

trolley height	trolley width	trolley depth (loaded)	30 chairs height	45 chairs height
835	580	1000	1530	1995

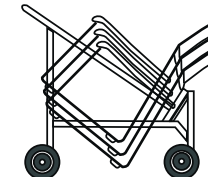
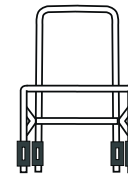

DAYLIGHT	FEATURES	BENEFITS
Solid oak stacking chairs best suited for chancel areas, side chapels, chapter-houses, parish churches	Exceptional stacking capacity (45 high)	Ideal for buildings with a high 'churn' rate. Economic storage
	Just 4 kg	About 40% lighter than other stacking chairs on the market
	Light - visually	Low impact on sensitive interiors (as seen in St Paul's, Ely and Salisbury cathedrals)
	Trolleys available	Easy deployment, recovery and storage. Up to 45 high
	20-30 year life expectancy	Very reasonable medium term investment
	Stacks up to 45 high	Economic storage
	Linking	Fitted as a standard feature
	Plastics - 100% recycled material	Ecologically sound
	Comfort	Strong, flexible mesh back provides maximum flex and tension in the back as well as breathability

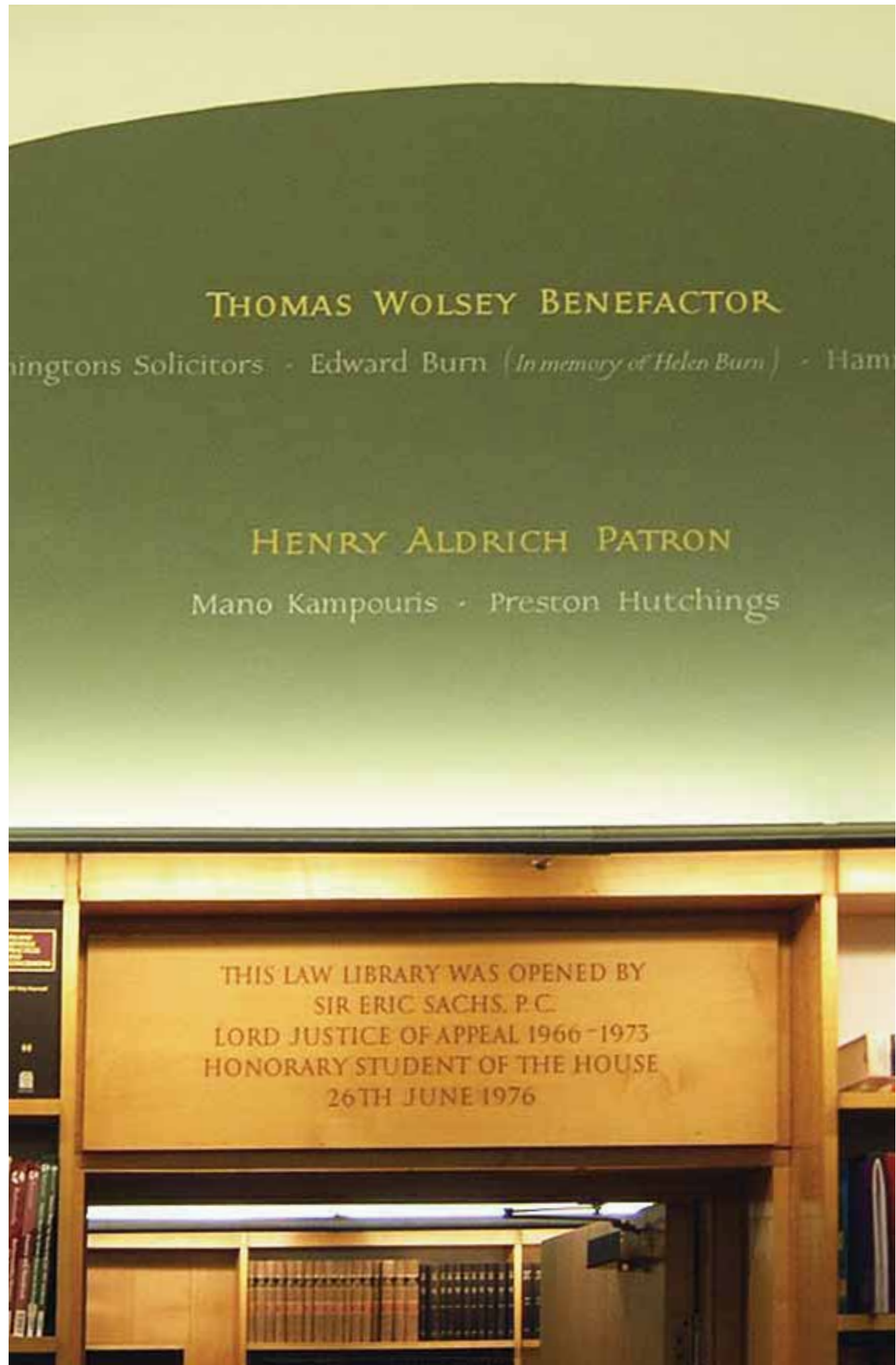

SPONSORSHIP & FUND RAISING

Luke Hughes & Company can advise on fund raising techniques



USEFUL CONTACTS

Advisory Board for Redundant Churches,
Church House, Great Smith Street, London SW1P 3NZ
tel 020 7898 1866

Ancient Monuments Society,
St Ann's Vestry Hall, 2 Church Entry, London EC4V 5HB
tel 020 7236 3934

Architectural Heritage Fund,
Clareville House, 26-27 Oxenden Street, London SW1Y 4EL
tel 020 7925 0199

The Art and Christianity Enquiry (ACE),
(The Revd Tom Devonshire Jones) 107 Crundale Avenue,
London NW9 9PS
tel 020 8206 2253

Association for Studies in the Conservation of Historic Buildings Institute of Archaeology,
31-34 Gordon Square, London WC1H 0PY
tel 020 7973 3326

Cathedral Architects Association,
Harcourt Offices, Hemingford Grey, Huntingdon, Cambs PE18 9BJ
tel 01480 461101

Church Monuments Society,
Dr Sophie Oosterwijk, 34 Bridge Street, Shepshed,
Leicestershire, LE12 9AD

Churches Conservation Trust,
1 West Smithfield, London EC1A 9EE
tel 020 7213 0660 e-mail central@tct.org.uk

Council for the Care of Churches,
Fifth Floor, Church House, Great Smith Street, London SW1P 3NZ
tel 020 7898 1866

Ecclesiastical Architects and Surveyors Association (EASA),
Elden Minns and Co Ltd, 453 Glossop Road, Sheffield S10 2PT
tel 0114 266 2458

Ecclesiological Society,
Hon Sec: Dr James Johnston, 143 Leithwaite Road, SW11 6RW
www.ecclsoc.org

English Heritage,
23 Savile Row, London W1X 1AB
tel 020 7973 3000 www.english-heritage.org.uk

Europa Nostra,
Lange Voorhout 35, 2514 EC The Hague, Netherlands
tel +(31) 70 3024050 www.europanostr.org

European Confederation of Conservator-Restorers' Associations,
Coudenberg, 70, 1000 Brussels
tel +(32) 2230 7291

Friends of City Churches,
St Margaret Pattens, Rood Lane, London EC3M 1HS
tel 020 7626 1555

Friends of Friendless Churches,
St Ann's Vestry Hall, 2 Church Entry, London EC4V 5HB
tel 020 7236 3934

Georgian Group,
6 Fitzroy Square, London W1T 5DX
tel 020 7529 8920 www.georgiangroup.org.uk
e-mail: georgian-group.org.uk

Guild of Architectural Ironmongers,
8 Stepney Green, London E1 3JU
tel 020 7790 3431

Heritage Lottery Fund,
7 Holbein Place, London SW1W 8NR
tel 020 7591 6000

Historic Churches Preservation Trust,
31 Newbury Street, London EC1A 7HU
tel 020 7600 6090 fax 020 7796 2442
e-mail: info@historicchurches.org.uk
www.historicchurches.org.uk

Institution of Structural Engineers,
11 Upper Belgrave Street, London SW1X 8BH
tel 020 7235 4535

International Institute for Conservation of Historic Art Works,
6 Buckingham Street, London WC2N 6BA
tel 020 7839 5975

Lead Sheet Association,
Hawkwell Business Centre, Maidstone Road, Pembury,
Tunbridge Wells TN2 4AH
tel 01892 822773

Liturgy Commission Office of the Bishops Conference of England and Wales, 39 Eccleston Square, London SW1V 1BX
tel 020 7620 8220

London Stained Glass Repository,
Glaziers' Hall, 9 Montague Close,
London SE1 9DD tel 020 7403 3300

Master Carvers Association,
Unit 20, 21 Wren Street, London WC1X 0HF
tel 020 7278 8759

Monumental Brass Society,
c/o Society of Antiquaries, Burlington House, London W1V 0HS
tel 020 7734 0193

National Heritage Memorial Fund,
7 Holbein Place, London SW1W 8NR
tel 020 7591 6000

National Monuments Record Centre,
Kemble Drive, Swindon, Wiltshire SN2 2GZ
tel 01793 414600

Save Britain's Heritage,
70 Cowcross Street, London EC1M 6EJ
tel 020 7253 3500

Society for the Protection of Ancient Buildings (SPAB),
37 Spital Square, London E1 6DY
tel 020 7377 1644

Stone Federation of Great Britain,
Construction House, 56-64 Leonard Street, London EC2A 4JX
tel 020 7608 5094

The Association of Technical Lighting and Access Specialists (ATLAS), 4D St Mary's Place, The Lace Market, Nottingham NG1 1PH tel 0115 955 8818

CLIENT COMMENTS

'Thanks for doing such an excellent job.

The benches look splendid...'

Head of Design, The British Museum (Nov 2000)

'The whole feel is of a place of quiet beauty - a comfortable and comforting place to be'.

Chairman of the Arts Council, about St George's, Brandon Hill (May 2000)

'The benches achieve a spectacular understatement and show us a different building. Can't wait to see more. And thanks to David Snell for such precise arrangements...'

Vicar, St Michael's Stourport (July 2000)

'The chairs look very good in the settings of both the Chapter House and the Cathedral and our credit to you and your craftsmen... you have made us a lovely product which draws appreciative comments for both appearance and comfort...'

Receiver-General, Canterbury Cathedral (Jan 2000)

'Members of the congregation were full of delight. I myself was thrilled by the quality of your workmanship...'

Canon Precentor, Rochester Cathedral (Nov 1999)

'I want to thank you for the wonderful tables which look lovely at Eltham Palace... Thank you for all your help and advice over the last few hectic months, it has been a pleasure working with you all'.
Hospitality Business Manager, English Heritage (July 1999)

'I wanted to say how much I have appreciated and admired your input and our dialogue at Pembroke. Your generous collaboration... has resulted in an all too rare contemporary synthesis between architectural space and furniture'.

Eric Parry, (on completion of the Nihon wing at Pembroke College, Cambridge; January 1998)

'I am writing to say... how delighted we are with the final design and especially the proportions and detailing and how marvellous is the craftsmanship of its execution. It is a fine tribute to your design skills and determination to get things exactly right and to the skill and perfectionism of the craftsmen who made it so beautifully. I would be grateful if you could pass on our thanks'.

Benefactors of St Barnabas, Dulwich (Dec 1997)

'We all think the Nihon Room looks absolutely spectacular. Your furniture... is really the piece de resistance'. Please extend my congratulations to everyone involved. We could not be more delighted'.

Bursar, Pembroke College, Cambridge (Dec 1997)

'Now that we have got the Queen's visit safely over I have time to write and say what a wonderful job you made of the new chapel benches. They look totally in keeping... the colour is well chosen... and those who have had time to study the benches closely comment on both the quality of design and manufacture... we were immensely relieved and not a little surprised that you managed to meet the delivery deadline despite the very short time available to you'.

Bursar, Charterhouse School (Feb 1997)

'May I express a word of appreciation for the very fine furniture which you provided... your design was widely acknowledged as being both imaginative and sympathetic to the building and the high standard of construction and the commendable service you provided have been praised...'

John Harris, Steward of Christ Church (November 1995)

'Your consistency of approach, attention to detail and patience in addressing small points of difficulty were exemplary and the outcome will be a source of satisfaction for many years to come'
Bursar of Newnham College, Cambridge (September 1994)

'The chairs are so handsome and have transformed two of the public rooms at the Society. Please pass on our thanks to all involved'.

Denise Prior, House Manager, Royal Geographical Society (March 1994)

'I am writing to say how very pleased we are with our new Hall chairs. Individually they look elegant; together and filling the hall they are magnificent... they have exceeded my expectations by a wide margin... May I congratulate your craftsmen on a job beautifully and skillfully executed; they can rightly be proud of their achievement...'

Bursar, Corpus Christ College, Cambridge (Oct 1992)

 LUKE HUGHES
AND COMPANY

182 Drury Lane Covent Garden London WC2B 5PP
T +44 (0)20 7404 5995 F +44 (0)20 7405 1839
E sales@lukehughes.co.uk W www.lukehughes.co.uk
Luke Hughes & Company Ltd is registered in England No 1952292

